

HSIN YUNG CHIEN CO., LTD.

Investor Conference

2021.12.17

Speaker : Stella

- 1- Company Profile**
- 2- Company Performance**
- 3- Product Introduction**
- 4- Q&A**

Hsin Yung Chien was established in 1964 in Nantou, Taiwan. Currently HYC is the biggest manufacturer in producing rubber conveyor belts in Taiwan and keeps on developing new equipment and renewing production procedure. HYC also has passed through ISO9001 and ISO14000 certificate and product lines include light and heavy-duty conveyor belts in wide range of application such as mining, steel, aviation, agriculture, logistics and pier automatic production line by "KING" brand in global market.

“NEWsheet”, the high polymer product line is complete and the R & D team is with rich experience to meet customers' demand in full range quickly.

The traditional production mode and method is replaced by the latest process technology and automatic equipment to supply high value-added services and excellent quality for market differentiation in global market.



Adds : NO.294 Nan kung 3RD Nan kung industrial Zone Nantou,Taiwan

TEL:+886492263888 FAX:+886492263168

Company History

<p>1964 Establishment In Taichung</p>	<p>1978 Take over by current chairman, Mr. Lin</p>	<p>1980 Factory moved to Nantou</p>	<p>1985 Certificated by CNS</p>	<p>1994 5-year Investment plan</p>	<p>1995 Certificated by ISO9001 Promotion of Kevlar belt</p>				
<p>1996 4th Session Outstanding SME Award</p>	<p>2000 2nd Session Rising Star Award</p>	<p>2002 Awarded by EPBA, Park Beautifying Championship, SME Golden Award</p>	<p>2003 Company name changed to Hsin Yung Chien. 1st Session Golden Rooting Award</p>	<p>2004 Company stock pre-listing</p>	<p>2005 14th Session National Award</p>				
<p>2006 Company stock listing Automatic Storage system built</p>	<p>2007 Finished 1st factory and Dipping fabric factory</p>	<p>2008 Finished 4th factory and got ISO 14001 Certificate.</p>	<p>2010 Stock market listed in Taiwan and got OHSAS 18001</p>	<p>2011 Industrial Sustainable Excellence Award</p>	<p>2012 Investing Steel Cord and Rubber Dam Facilities</p>				
<p>1978~1990 夾縫中求生存</p>	<p>1991~1999 天翻地覆</p>	<p>2000~2004 孤注一擲</p>	<p>再吹蛻變</p>	<p>躍馬揚鞭</p>	<p>2020 Build new 6 floors factory at original 4th factory in 2021 .</p>	<p>2019 Finished 5th factory</p>	<p>2018 Announced lightweight and recycled luggage</p>	<p>2015 1st Taiwan Mittelstand Award</p>	<p>2013 1st Backbone enterprise key counseling object</p>

Factories





Factory Environment

Winner of Green and Landscaping among all the factories of 2003 & 2012 in Taiwan



	2016	2017	2018	2019	2020	2021. Q3
Net Sales	1, 561, 379	1, 633, 863	1, 843, 877	1, 658, 837	1, 596, 510	1, 424, 778
Gross Profit	597, 962	579, 888	640, 327	608, 209	664, 702	606, 925
Gross Profit Ratio	38%	35%	35%	36%	42%	43%
Operating Income	455, 299	444, 512	483, 578	455, 402	508, 135	393, 942
Non-operating Income& Expenses	(25, 904)	(36, 132)	3, 352	45, 110	110, 383	475, 518
Income Before Tax	429, 395	408, 380	486, 930	500, 512	618, 518	869, 460
Net Income	350, 227	338, 923	394, 842	399, 524	523, 696	796, 218
EPS	5. 19	5. 02	5. 85	5. 63	7. 39	10. 21(註)

Remark: The surplus was converted into capital increase in September 2021 and the weighted average number of outstanding shares was 77,992 .

Sales Trend

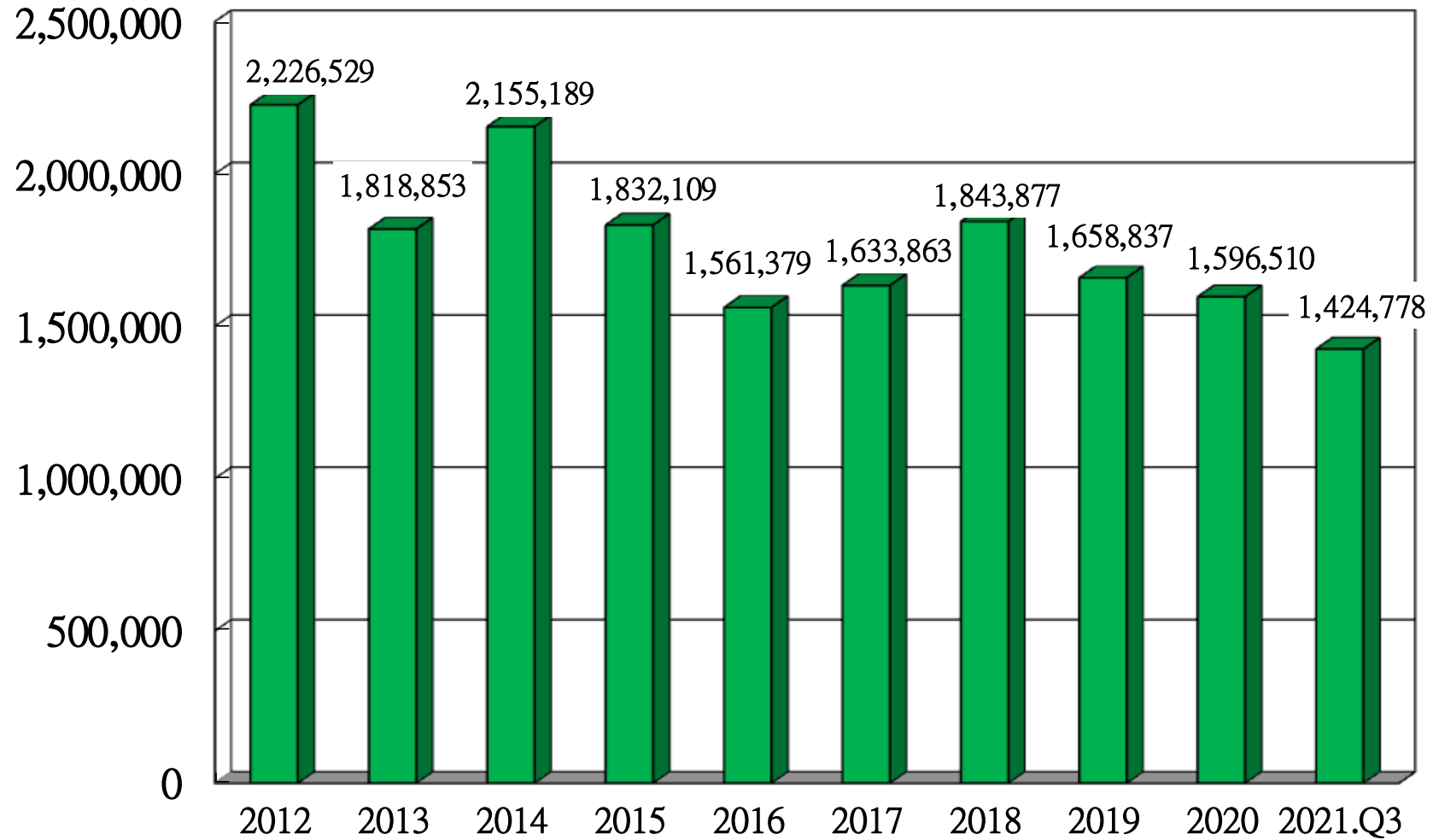

Income Before Tax

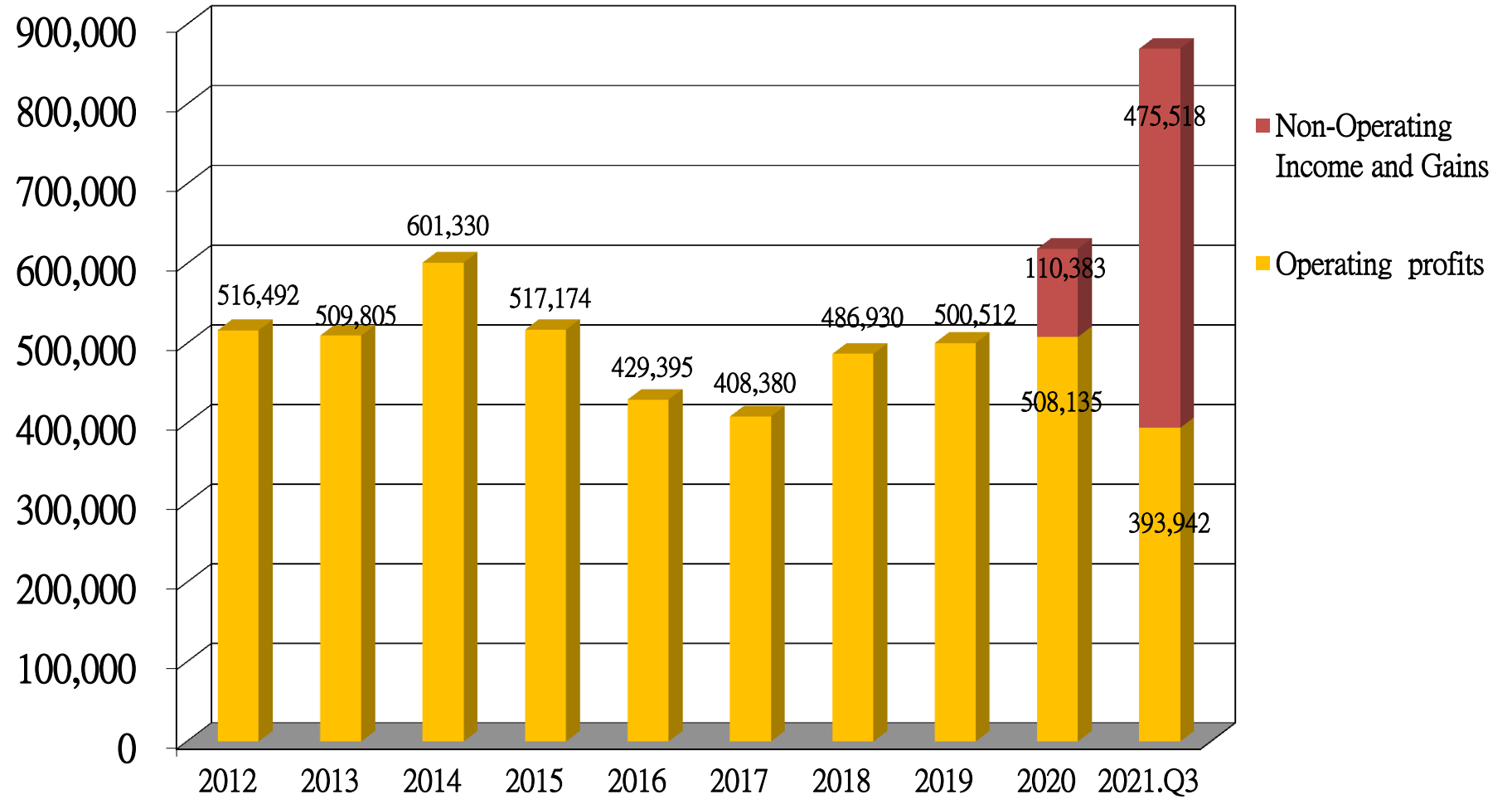

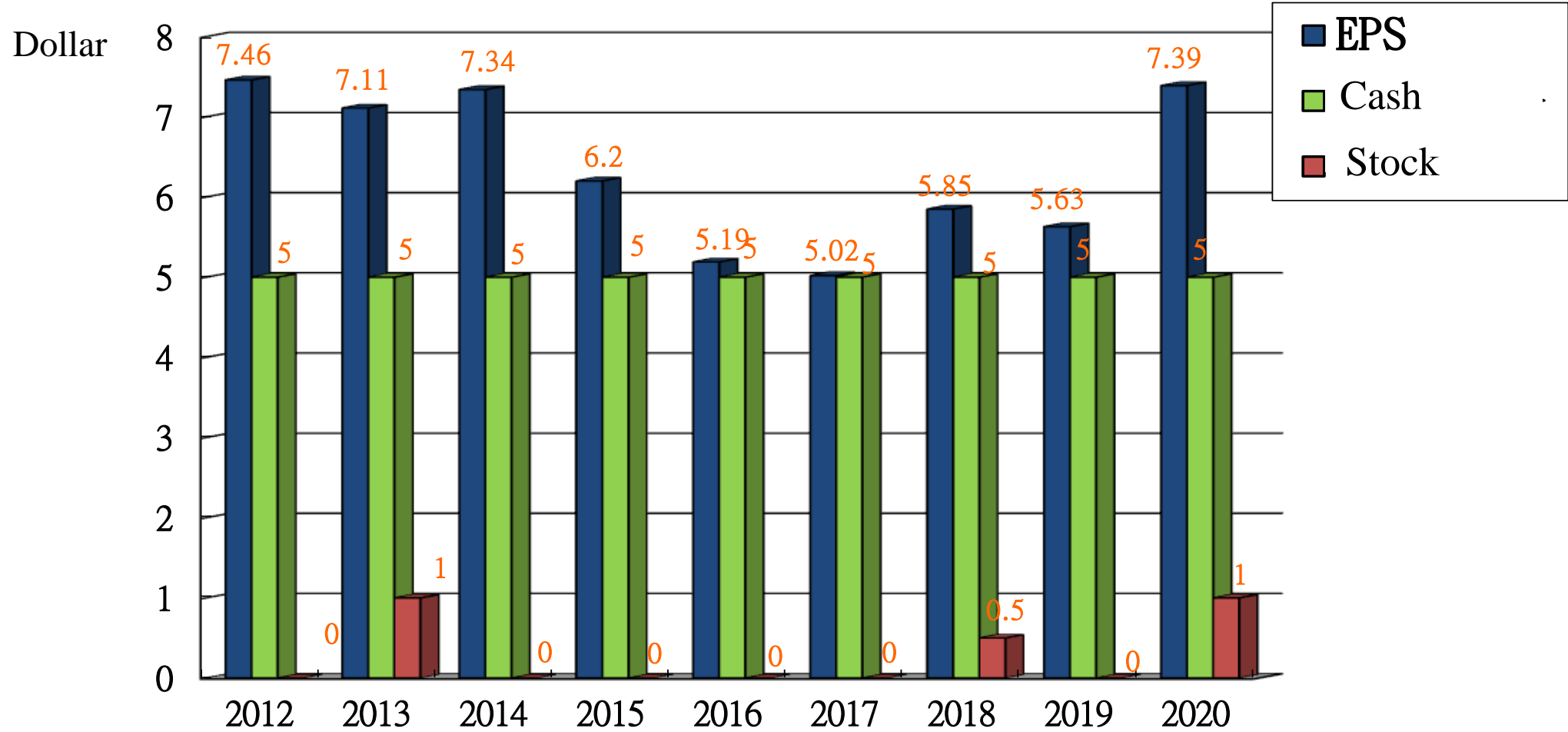

Product	Application
<p>Flat Conveyor Belt Steel Cord Conveyor Belt</p>	<p>Quarry, Cement plant, Power plant, Steel Plant.</p>
<p>Patterned Belt Logistics Belt Chevron Belt</p>	<p>Logistics, Electronics, Textile, Animals, Agriculture, Inclined transportation.</p>
<p>Heat resistant, Oil resistant, Flame resistant, Impact resistant, Rip-stop Conveyor Belt</p>	<p>Fertilizer, High-temperature environment, Coal Mining, Sharp materials.</p>
<p>Rubber Dam 、 Wave Sheet</p>	<p>Water resource, Recycle, Environmental beautification, Park. ’ Wave Power</p>





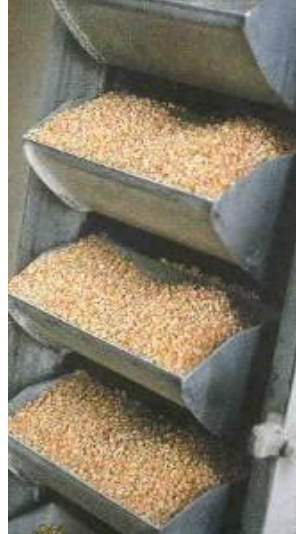

HYC Application – Agriculture / Logistics





Rubber Dam

Landscape



Power



Flood Protection



Irrigation



Water Storage



Ecology



Rubber Dam 3D Picture

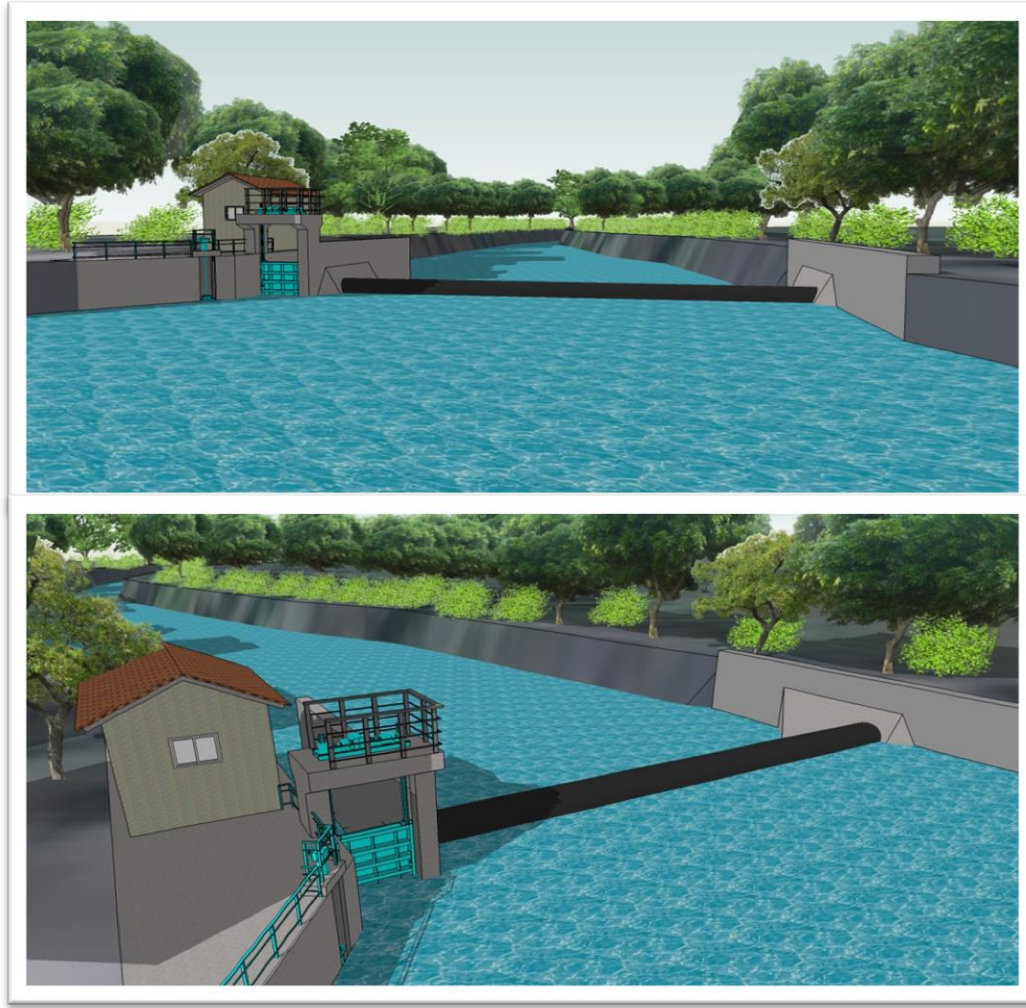

Steel Gate 3D Picture

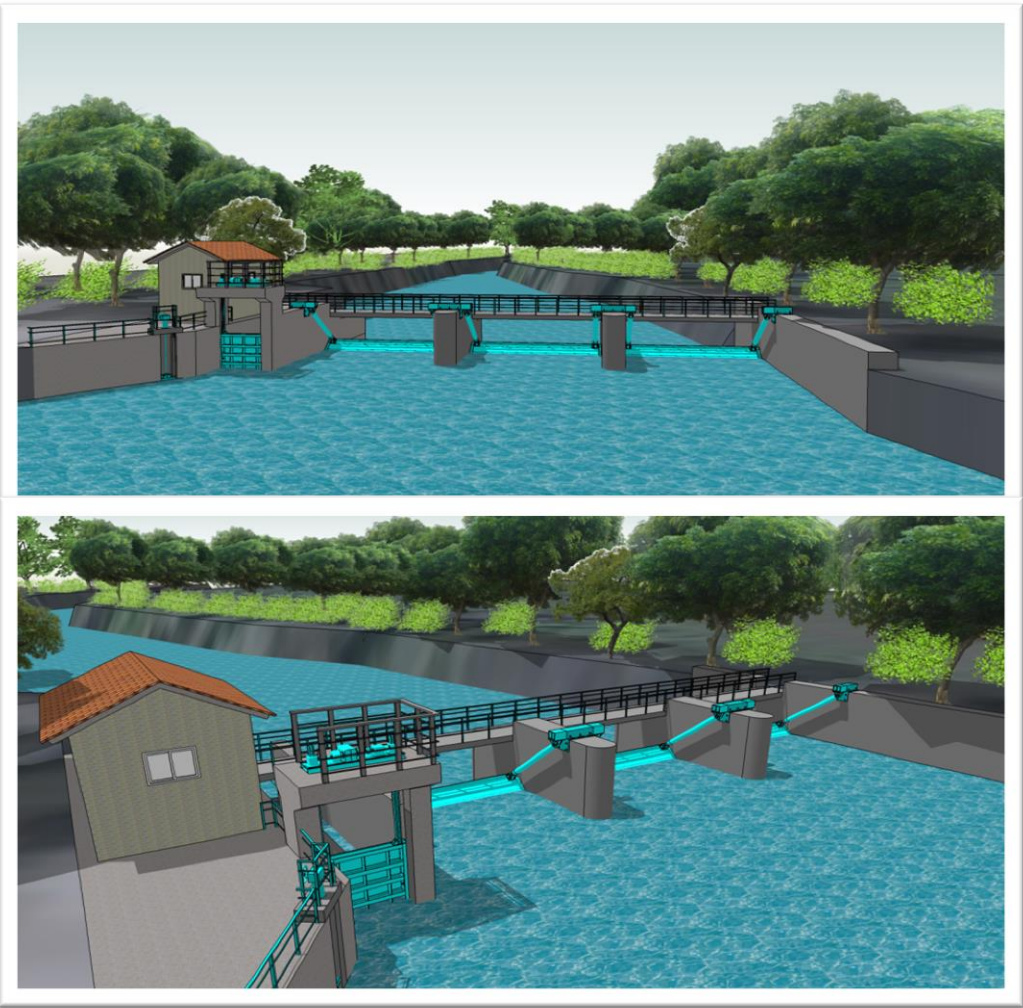



Rubber Dam Facilities:

Max. producible width can reach 12-meters wide with unlimited length, producing products like Rubber Dam or Rubber Flooring. , Wave Sheet for Power

HYC Rubber Product Application (Wave Power)

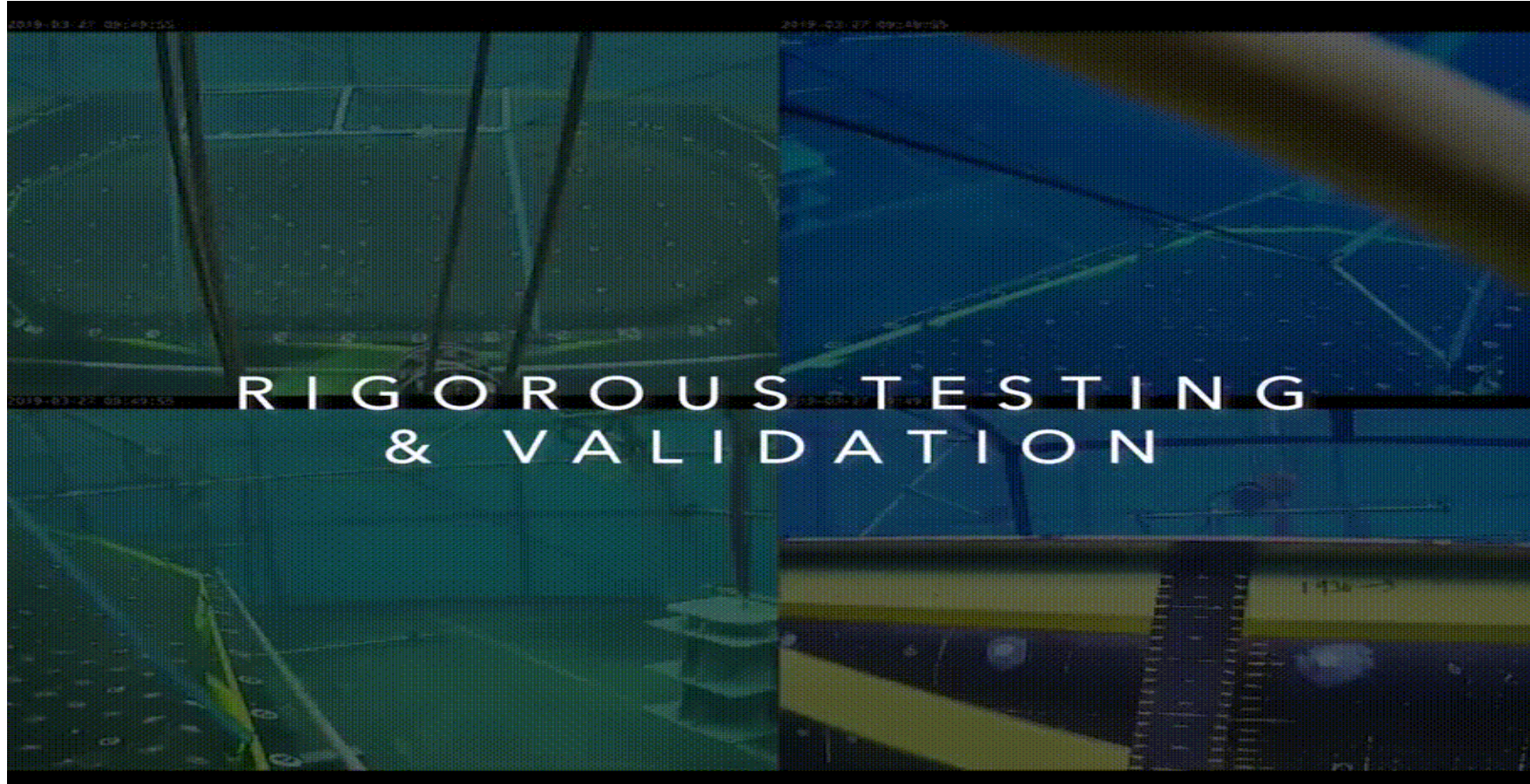

HYC Rubber Product Application (Wave Power)

■ System Performance Design

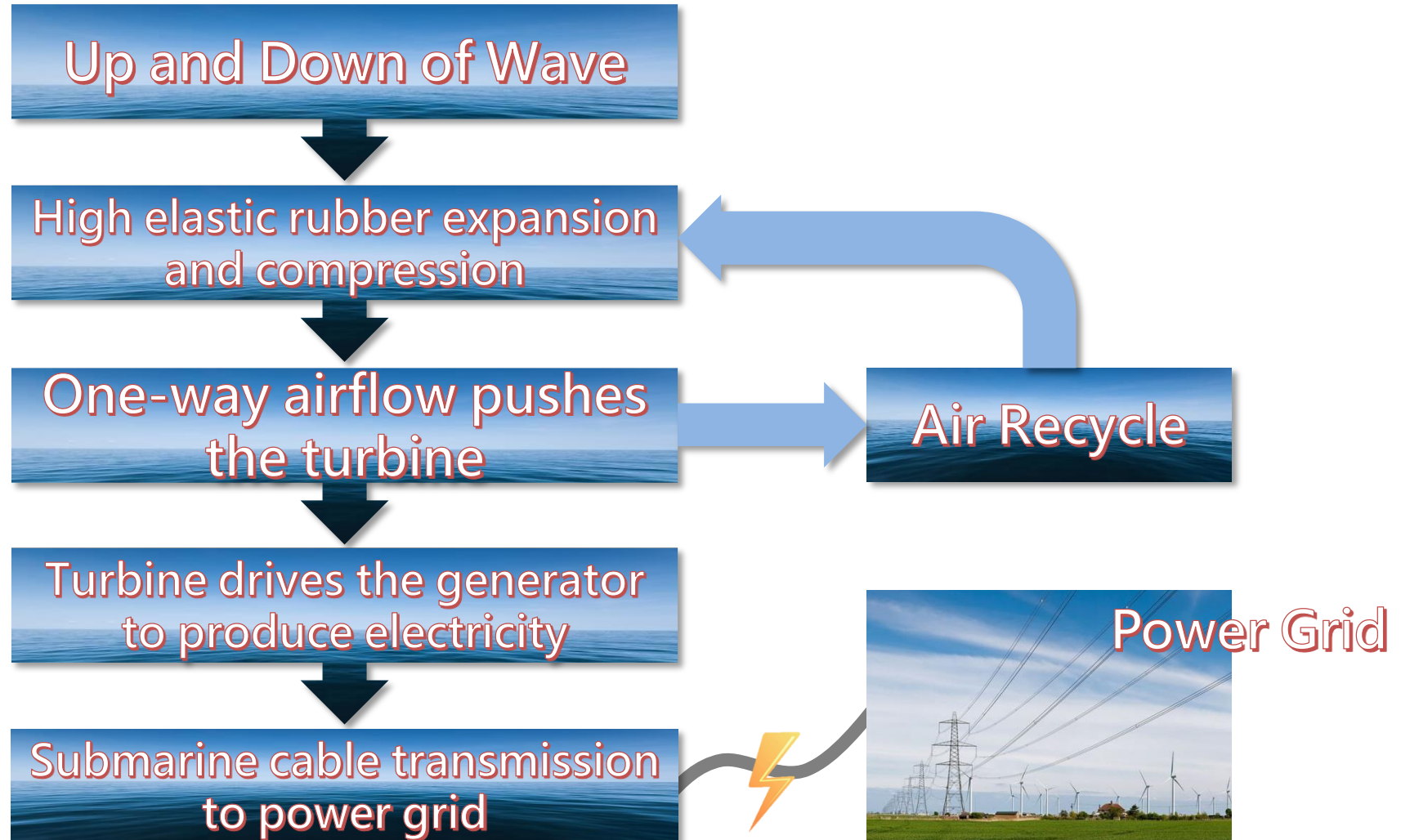

HYC Rubber Product Application (Wave Power)

■ System Features:

- Convert into electricity by nature's waves.
- **Does not affect** maritime activities on the sea.
- **Stable Power.**
- Easy operate and maintain by the equipment of **modularization.**
- Lifetime of Design : **20 years.**
- **Environmental Friendly** and **no pollution** for operation and recycle after use.
- Approaching **base load** power (24 hrs/day x 7 days/week).
- Power : **4MW~8MW** / set

HYC Rubber Product Application (Wave Power)

■ System Style

● Fix

- **Fix on the seabed near the shore.**
- **Set the internal pressure according to the depths of different seabed.**

● Snorkel

- **Set in the farther sea area from the shore to obtain greater wave power.**
- **Sense the height of the waves by buoys and adjust the depth of snorkeling.**

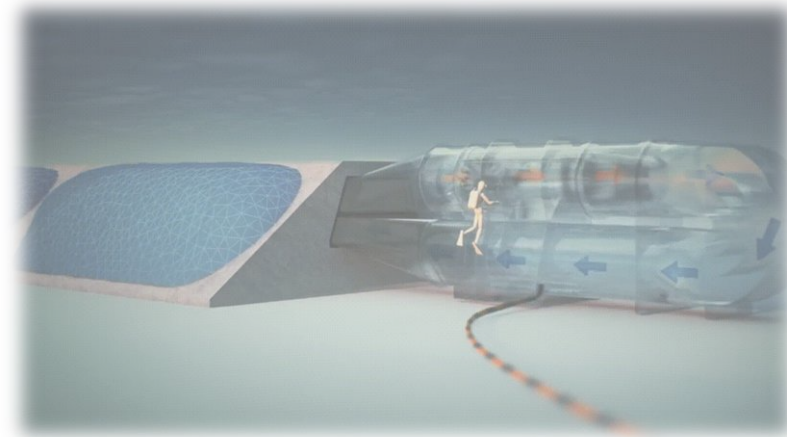



KEY CONSUMABLES FOR FUTURE

Main Products :

1. Eco-friendly hot-press cushion pad

(Awarded Gold Medal by 63rd International Invention Exhibition in Nuremberg, Germany in 2011.

2. NEWsheet Serial Products

Hot-press cushion pad

With 50-year experience of production and rubber development technology, we have developed this stable, manageable, and recyclable cushion pad.



Patented by
M551128
M551122

1-ton Kraft paper
can be replaced by 2 pcs of
cushion pad

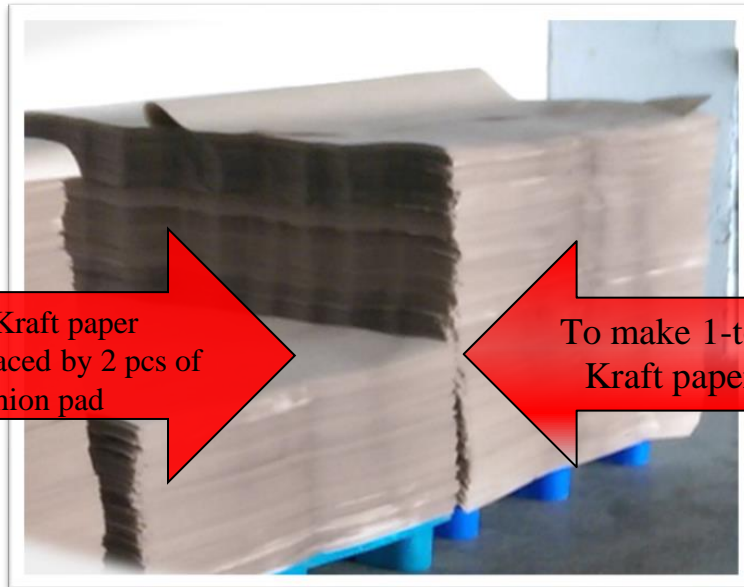

To make 1-ton
Kraft paper

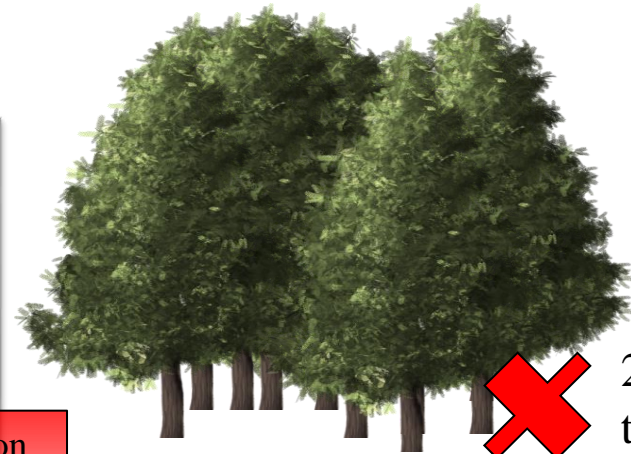

20
trees



100
buckets

The procedure of PCB pressing, which uses a lot of Kraft paper, will impact on :

- ◆ Factory Cleanliness
- ◆ Bad Odor
- ◆ Waste of storage space for stock
- ◆ Waste of materials transportation
- ◆ Management

Advantages

- Sealing on both sides makes products firm, breathable, and moisture proof.
- Controlling times of pressing by QR code.
- 40% lighter than other manufactures' products.
- Long-lasting lifetime (CCL-500 times, PCB-300 times)
- Flexible but strong.
- Automatic

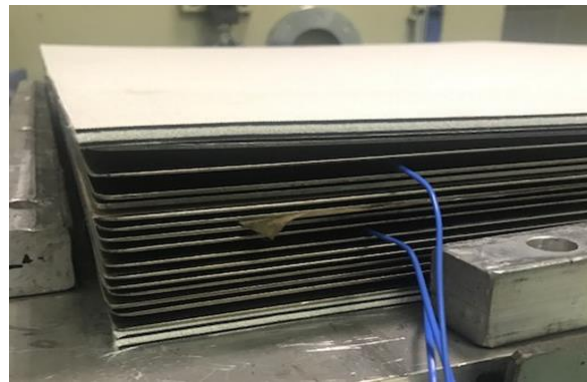

With the rise of environmental protection issues, both the EU and advanced countries have planned with waste reduction and value creation goals for circular economy. Therefore, the characteristics of waste reduction and recyclability have become important considerations when developing new materials and new products.

Thermoplastic carbon fiber composite products have excellent characteristics such as light weight, toughness, good processing and environmental protection and recyclability, which can meet the requirements of circular economy. °

The global composite material market demand ratio and amount (AVK statistics to 11/2018), the share of resin-based composite materials is about 16.48 billion US dollars.

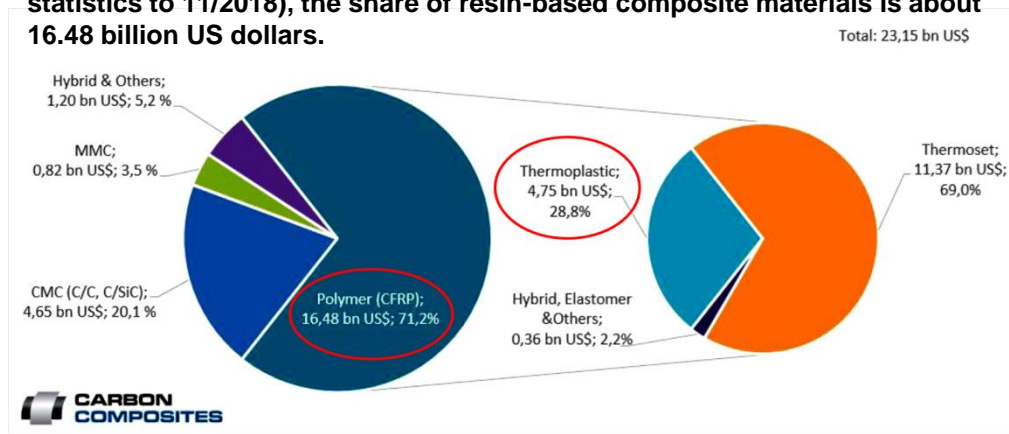

Global composite materials market demand ratio and amount

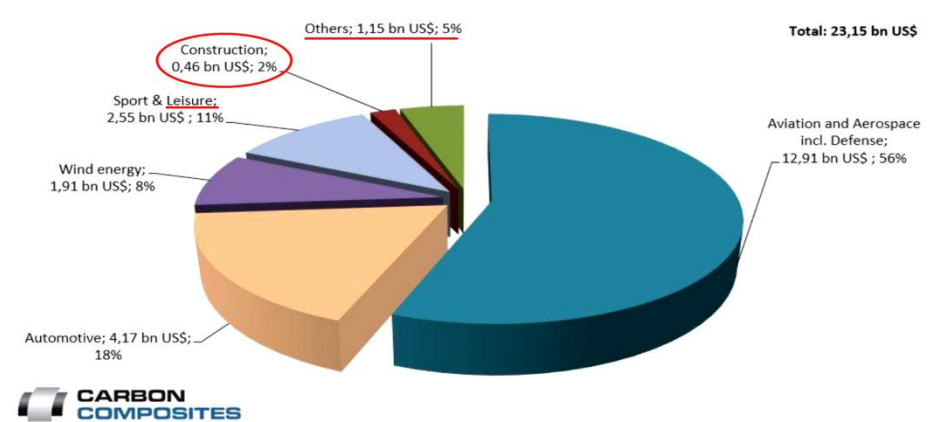

According to AVK analysis of German , the global thermoplastic carbon fiber composite material market has reached 4.75 billion US dollars in 2018 (28.8%).

the global thermoplastic composites market share forecast will reach 41.9 billion US dollars in 2022 by Markets and Markets analysis.



Composite Carbon Fiber Waste



With the rapid development of the wind power industry and the continuous increase in the size of wind turbine blades, it is estimated that by 2034, the global waste of thermoset carbon fiber composite materials will reach more than 225,000 tons.

At present, there are over 2 million tons of composite waste between Taiwan and China. It is estimated that more than 100,000 tons of new waste will be added every year.

Data From : Science Development 2019 NOV. NO.563

The features of thermoplastic composites are light, thin, tough, good processing, durability and environmental protection from materials to livelihood supplies and based on environmentally friendly re-use and recycling to create the continuous chain circulation system which is the future goal of Newsheet.

- ◎ **5+N Driven by industry demand** — Automation, Energy Saving and Recycling Economy
- ◎ **Lightweight and High Strength** — Replace metal or plastic
- ◎ **Appearance. Color and Unique Pattern** — Focus on appearance
- ◎ **Large Number for Require** — With plastic injection process (cost)
- ◎ **Plastic processing bottleneck** — Big Size. High rigidity. Process Yield and Capacity

Features of Material:

1. Recycling long carbon fiber material
2. Heat resistant up to 320 Celsius
3. Repeat manufacturing available
4. High strength to replace metal
5. Lightweight in different shapes
6. Available for industry usage.



Newsheet-Lightweight Environmental Friendly Composite Formwork

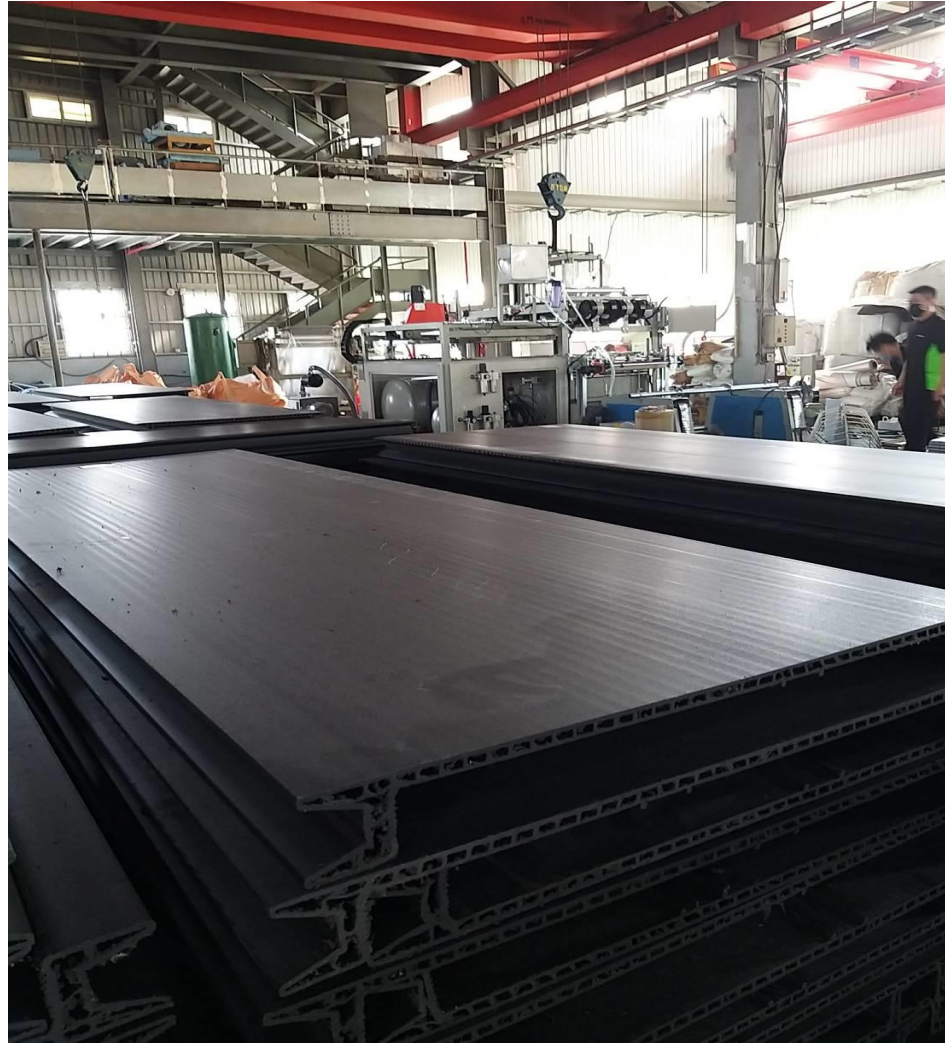

Environmental Friendly Composite Formwork – Easy Installation

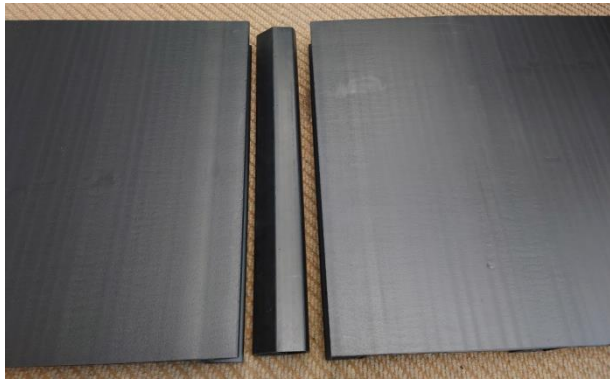

Connecting Support



Corner Support

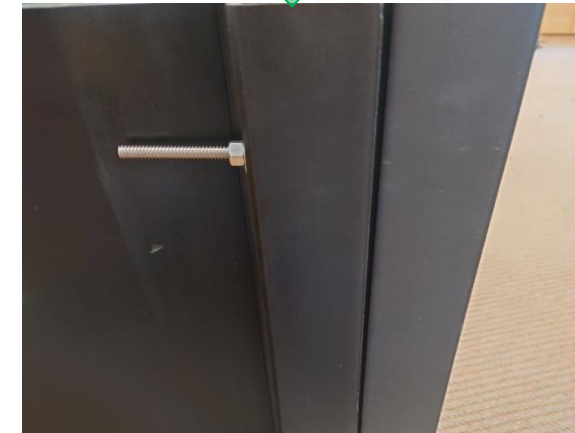

Side Support

M12 hexagon socket screw and Anka screw for easy installation.



Environmental Friendly Composite Formwork – Easy Installation

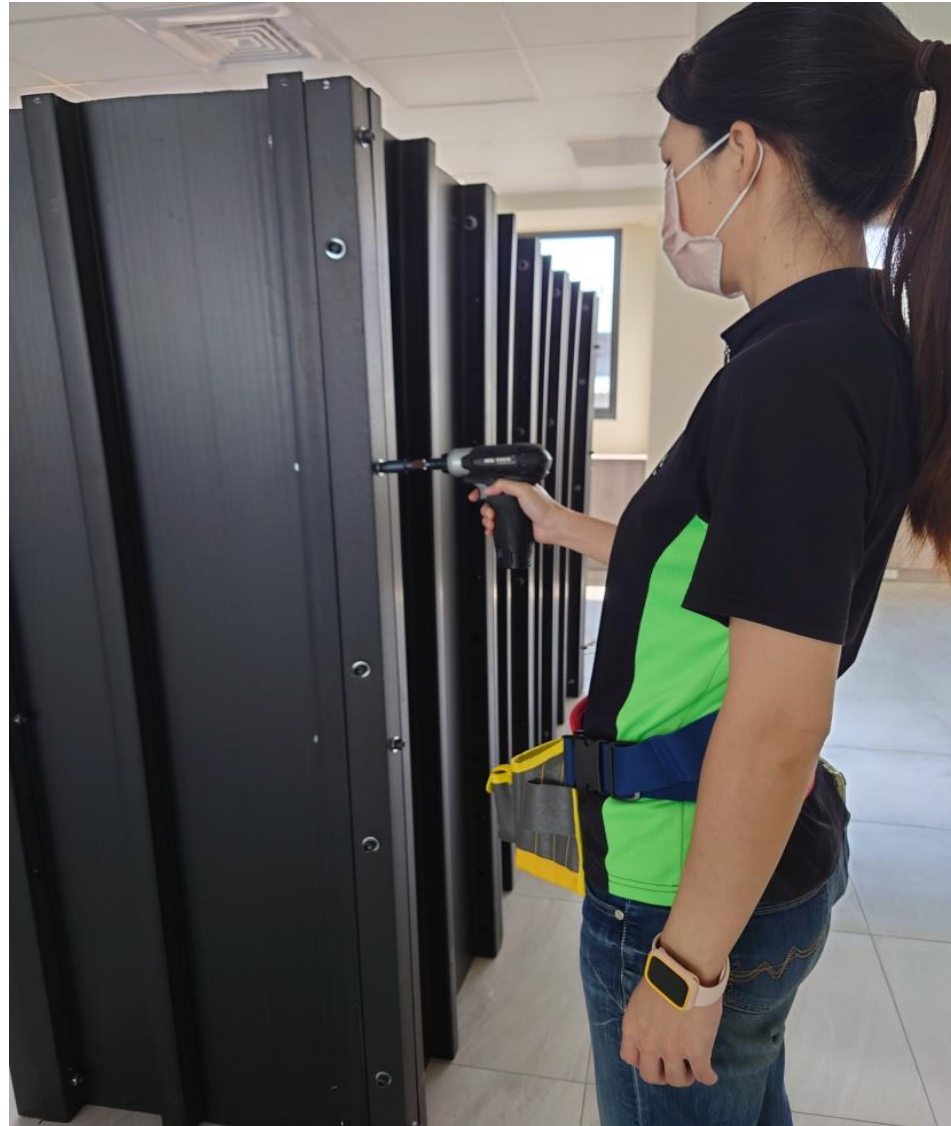

- *It's easy for woman to install by M12 hexagon socket screw and Anka screw with electric screwdriver.**
- *Reduce formwork process technology.**
- *Other accessories are same as wooden formwork.**
- *Work with current wooden formwork.**

Light Easy move 600mm X 1,820mm 14KG/PC

**Easy Easy installation as building blocks.
Exclusive Bracket for moving and collection.**

Saving High flatness by fair-faced concrete can save the cost of second processing. Wall face by pattern of formwork for tiles can save second processing. Over 30 times of use.

**Durability Durable, Corrosion-resistant, Aging-resistant,
non-absorbent, Moisture absorption. Heat preservation.**

Environmental Friendly 100% Recycle

Formwork Comparison Chart

	Composite Formwork	Wooden Formwork	Steel Formwork
Weight	Light	Middle	Heavy
Time of Use	Over 30 times	5~6 times	Around 40 times
Price	Middle	Cheap	Expensive
Flame retardant	B1 level	Non-flame	Yes
Releasing	Easy	Moderate	Difficult
Processing	Good	Good	Bad
Corrosion resistance	Good	Bad	Bad
Recycle	Yes	No	Yes
Water absorption	Non-absorption	Easy Deformed	Easy Rust
Hardness Surface	High	Normal	Higher
Deformed	Small	Small	Small
Maintain	Water clean	By Diesel	By Anti-rust oil
Range of Work	For all range	For all range	Public construction



Environmental Friendly Composite Formwork Storage

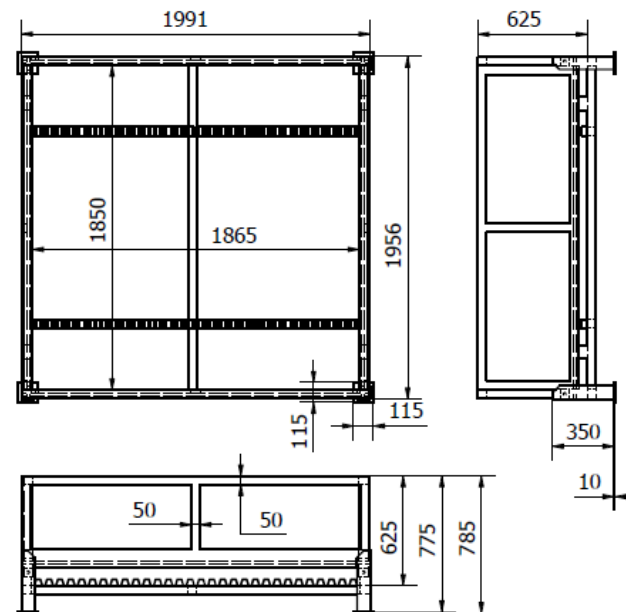
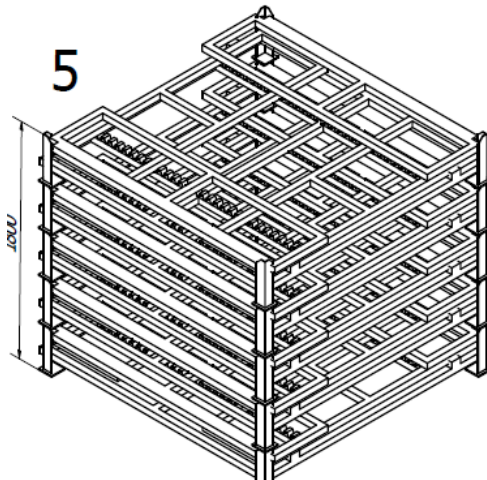
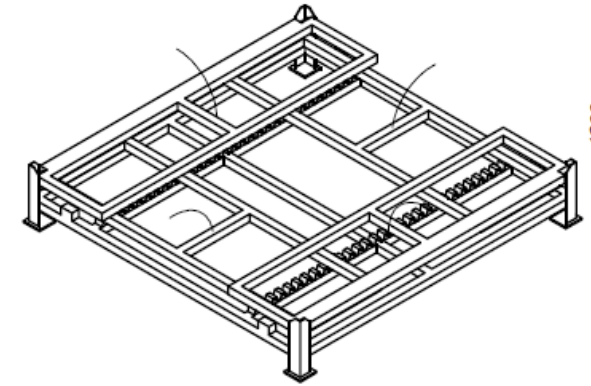
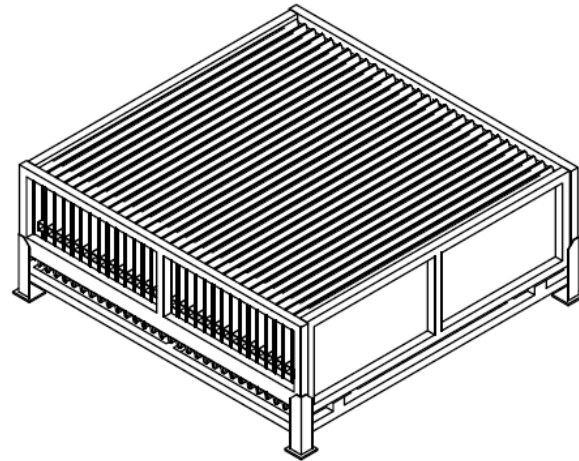
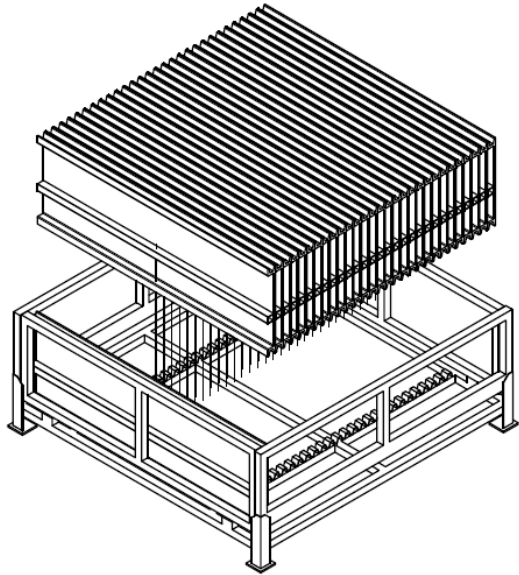

***After use, the formwork can be collected in the exclusive bracket.**

***30 pcs storage in one bracket for easy arrangement and transportation.**

***The bracket can be folded for saving space.**

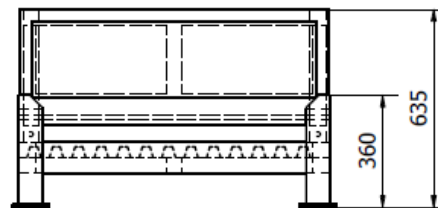
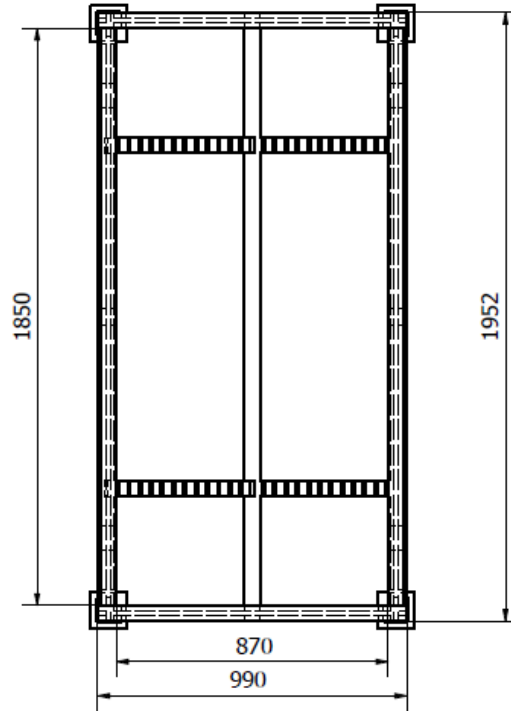
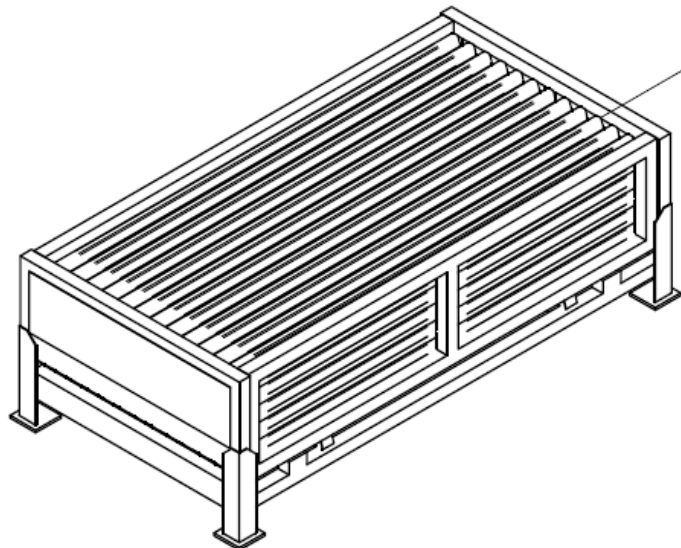
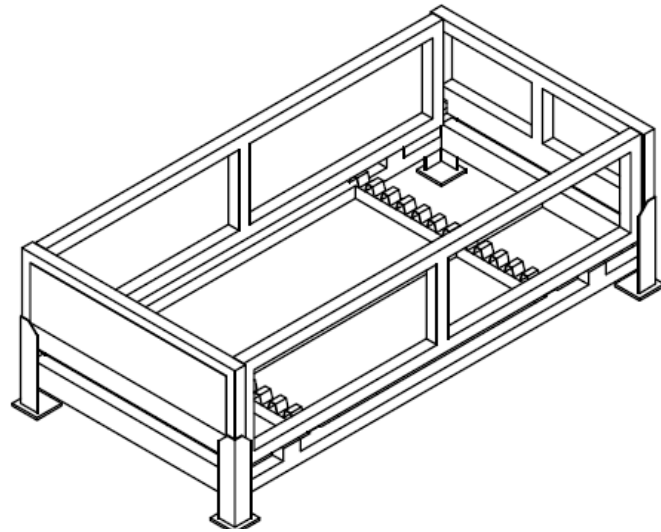

- *After use, the support can be collected in the exclusive bracket.**
- *144 pcs storage in one bracket for easy arrangement and transportation.**
- *The bracket can be folded for saving space.**

HYC Environmental Friendly Composite Formwork Use



Thank you for listening

